

M-1iA/1H



Max. load capacity
at wrist: **1 kg**



Max. reach:
280 mm

Controlled axes	Repeatability (mm)	Mechanical weight (kg)	Motion range (°)							Maximum speed (°/s)							J4 Moment/ Inertia (Nm/kgm ²)	J5 Moment/ Inertia (Nm/kgm ²)	J6 Moment/ Inertia (Nm/kgm ²)
			J1	J2	J3	J4	J5	J6	E1	J1	J2	J3	J4	J5	J6	E1			
3	± 0.02	18 *2	∅ 280 x 100 *3			-	-	-	-	-	-	-	-	-	-	-		*4	

Working range

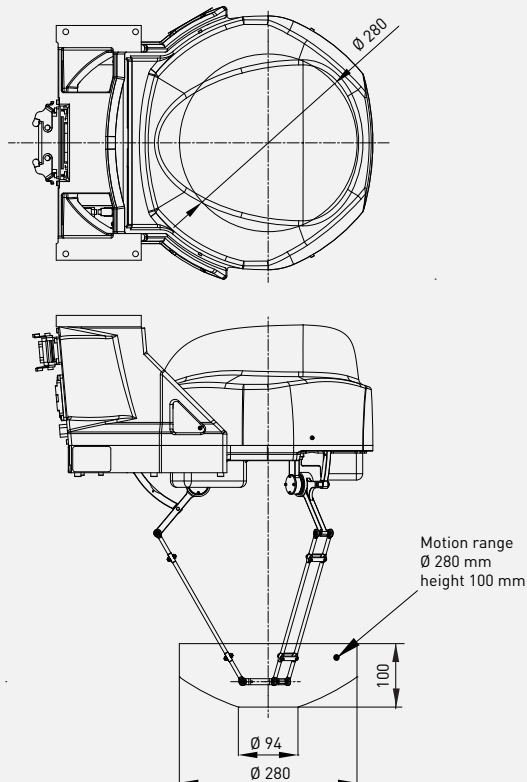

Robot

	M-1iA/1H
Robot footprint [mm]	134 x 370
Mounting position Floor	●
Mounting position Upside down	●
Mounting position Angle	-

Controller

	R30iB
Open air cabinet	●
Mate cabinet	○
A-cabinet	-
B-cabinet	-
iPendant Touch	●

Electrical connections

Voltage 50/60Hz 3phase [V]	-
Voltage 50/60Hz 1phase [V]	220-230
Average power consumption [kW]	0.2

Integrated services

Integrated signals on upper arm In/Out	6/6
Integrated air supply	1

Environment

Acoustic noise level [dB]	61.2
Ambient temperature [° C]	0-45

Protection

Body standard/optional	IP20
Wrist & J3 arm standard/optional	IP20

*2] with stand *3] ∅ in mm by height in mm *4] refer to the wrist load diagramm
 ● standard ○ on request - not available () with hardware and/or software option