

# M-410iB/700 (Hollow wrist)



Max. load capacity  
at wrist: **700 kg**



Max. reach:  
**3143 mm**

Controlled axes	Repeatability (mm)	Mechanical weight (kg)	Motion range (°)						Maximum speed (°/s)						J4 Moment/ Inertia (Nm/kgm <sup>2</sup> )	J5 Moment/ Inertia (Nm/kgm <sup>2</sup> )	J6 Moment/ Inertia (Nm/kgm <sup>2</sup> )
			J1	J2	J3	J4	J5	J6	J1	J2	J3	J4	J5	J6			
4	± 0.5	2700	360	144	136	540	-	-	60	60	60	120	-	-	490	-	-

## Working range

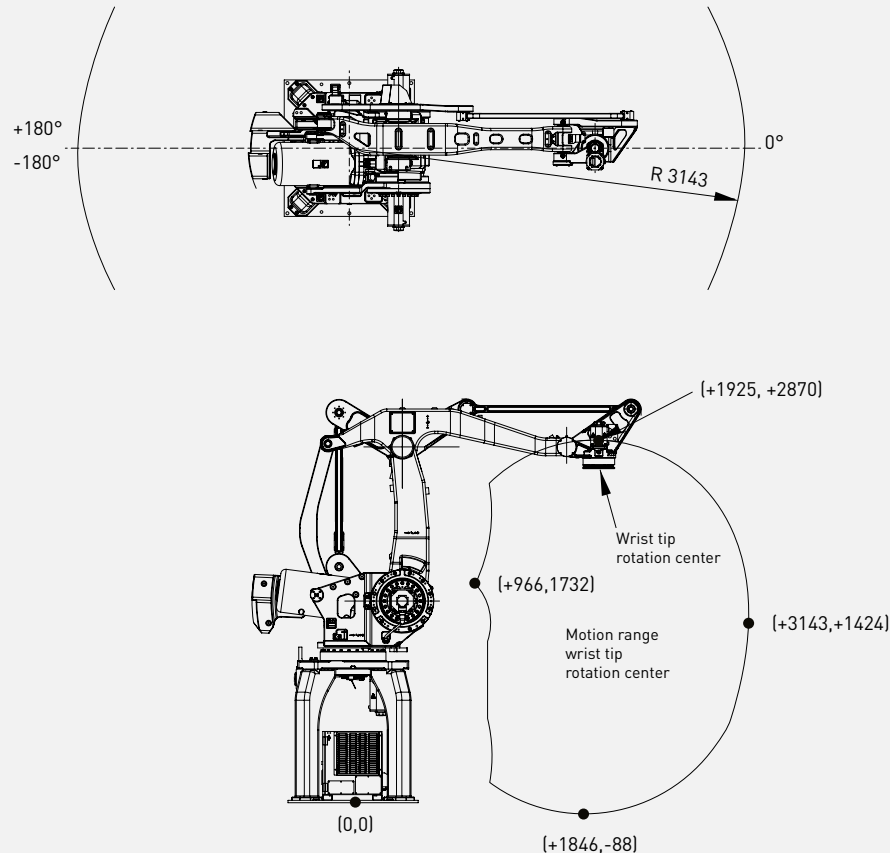

### Robot

### M-410iB/700

Robot footprint [mm]	1080 x 1030
Mounting position Floor	●
Mounting position Upside down	-
Mounting position Angle	-



### Controller

### R30iB

Open air cabinet	-
Mate cabinet	-
A-cabinet	●
B-cabinet	○
iPendant Touch	●

### Electrical connections

Voltage 50/60Hz 3phase [V]	380-575
Voltage 50/60Hz 1phase [V]	-
Average power consumption [kW]	1

### Integrated services

Integrated signals on upper arm In/Out	8/8
Integrated air supply	1

### Environment

Acoustic noise level [dB]	< 70
Ambient temperature [° C]	0-45

### Protection

Body standard/optional	IP54
Wrist & J3 arm standard/optional	IP54

● standard ○ on request - not available ( ) with hardware and/or software option